

HTD Pulleys Profile 8M

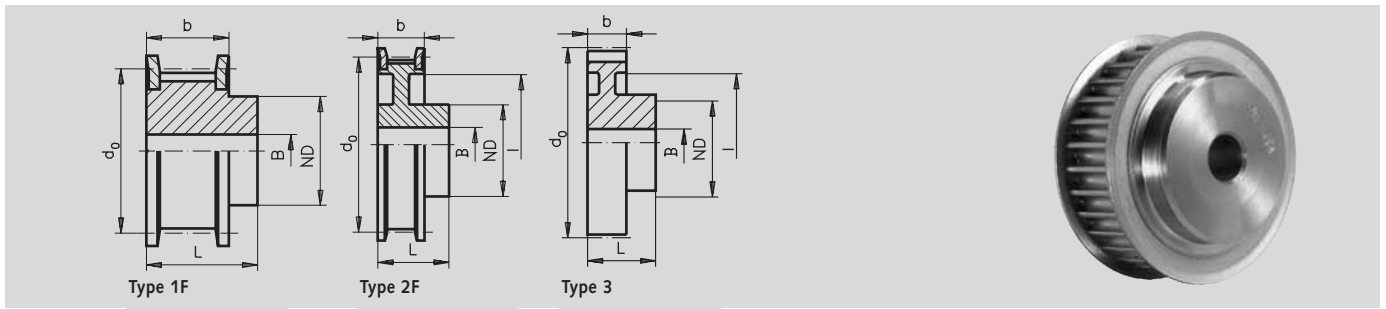

Material: phosphated steel.

The functionality of a V-belt drive is largely influenced by the quality of the used pulley. HTD pulleys are precision components, manufactured pitch-true with special cutters. This leads to a precise meshing of teeth.

Ordering Details: e.g.: Product No. 174 411 00, Pulleys, Pitch 8 mm, 22 Teeth, Timing Belt Width 50 mm

Profile 8M, Timing Belt Width 50 mm

Product No. Timing Belt Width 50 mm	Number of teeth	Type	Outside Ø		d ₀ mm	ND mm	b mm	L mm	I mm	Pilot Hole B mm	Custom Bore B max. mm	Weight g
			Pulley mm	Flange mm								
174 411 00	22	1F	54.65	60.0	56.02	43	60	70	-	12	25	1100
174 412 00	24	1F	59.75	66.0	61.12	45	60	70	-	12	28	1300
174 413 00	26	1F	64.85	71.0	66.21	48	60	70	-	12	30	1600
174 414 00	28	1F	70.08	75.0	71.30	50	60	70	-	14	30	1700
174 415 00	30	1F	75.13	83.0	76.39	55	60	70	-	14	32	2000
174 416 00	32	1F	80.16	87.0	81.49	60	60	70	-	14	35	2350
174 417 00	34	1F	85.22	91.0	86.58	66	60	70	-	14	42	2800
174 418 00	36	1F	90.30	98.5	91.67	70	60	70	-	14	42	3150
174 419 00	38	1F	95.39	103.0	96.77	75	60	70	-	14	45	3300
174 420 00	40	1F	100.49	106.0	101.86	75	60	70	-	14	45	3600
174 422 00	44	1F	110.67	119.0	112.05	75	60	70	-	14	45	4400
174 424 00	48	1F	120.86	127.0	122.23	75	60	70	-	14	45	5000
174 428 00	56	2F	141.23	148.0	142.60	90	60	60	116	18	50	5680
174 432 00	64	2F	161.60	168.0	162.97	100	60	60	137	18	50	6930
174 436 00	72	2F	181.97	192.0	183.35	100	60	60	158	18	55	7950

Timing belt width 85 mm available on request.