

Clamping Bushes MSA

Material: Steel.

Mechanical, all-steel clamping elements, containing no hydraulic pressure medium. Both ①. inner and ②. outer part have a cylindrical buttress thread with a lengthwise slot. The ③. inner ring connected to the inner part has ④. threaded studs, that create a tensioning effect when tightened. The bushes are designed for very high loads in radial as well as in axial direction. The axial runout does usually not exceed 0.02 mm. If a clamping bush without slot on the outside part is to be welded onto a workpiece, we would ask you to contact us first. Feather key grooves in the shaft do not cause any problems; simply remove the frictional corrosion.

Tolerance: Shaft h11 up to k6, Hub H7 up to H11

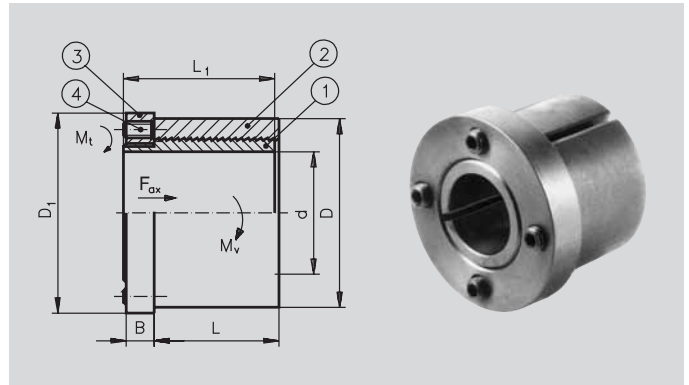

Ordering Details: e.g.: Product No. 615 019 00, Clamping Set MSA, Slotted, 19 mm

Product No.	d mm	D mm	D ₁ mm	L mm	L ₁ mm	B mm	Surface Pressure ¹⁾ N/mm ²	Threaded Studs		Required Fastening Torque M _t Nm	Transmittable Torque max. M _v Nm	Permissible Axial Force F _{ax} kN	Weight kg
								Amount Pieces	Thread mm				
615 019 00	19	42	49	27	36	9.5	42	4	M 6 x 12	8	170	18	0.33
615 020 00	20	42	49	27	36	9.5	42	4	M 6 x 12	8	180	18	0.32
615 022 00	22	42	49	27	36	9.5	42	4	M 6 x 12	8	200	18	0.31
615 024 00	24	46	53	27	37	10.5	58	6	M 6 x 12	8	325	27	0.37
615 025 00	25	46	53	27	37	10.5	58	6	M 6 x 12	8	340	27	0.36
615 028 00	28	55	63	32	44	12.5	66	4	M 8 x 16	18	490	35	0.64
615 030 00	30	55	63	32	44	12.5	66	4	M 8 x 16	18	525	35	0.61
615 032 00	32	60	67	37	49	12.5	60	5	M 8 x 16	18	650	41	0.81
615 035 00	35	60	67	37	49	12.5	61	5	M 8 x 16	18	720	41	0.75
615 038 00	38	67	75	45	57	12.5	54	6	M 8 x 16	18	950	50	1.13
615 040 00	40	67	75	45	57	12.5	54	6	M 8 x 16	18	1000	50	1.06
615 042 00	42	67	75	45	57	12.5	54	6	M 8 x 16	18	1050	50	1.01
615 045 00	45	70	77	50	63	13.5	53	7	M 8 x 16	18	1280	57	1.17
615 048 00	48	77	83	55	68.8	14	50	8	M 8 x 16	18	1560	65	1.62
615 050 00	50	77	83	55	68.5	14	50	8	M 8 x 16	18	1625	65	1.53

¹⁾ approximate surface pressure between clamping bush and hub.

The values for the maximum transmittable torque and the maximum permissible axial force for the clamping bush at static load are stated in the table above. With dynamic load these values have to be reduced, i.e. divided by the operating factors listed in the adjoining table.

Operating factor f_b for various operating conditions

Drive Unit	Type of Load		
	Uniform Load	Moderate Shock	Strong Shock
Electric motors, turbines	1 - 1.25	1.25 - 1.5	1.5 - 1.75
Multi-cylinder piston engines	1.25 - 1.5	1.5 - 1.75	1.75 - 2
One-cylinder piston engines	1.75 - 2	2 - 2.25	2.25 - 3