

Slides 3832 DO, Width 12.7 mm, to 50 kg, Full Extension with Hold-In and Hold-Out

Material:

Slide elements: Cold-rolled steel, zinc plated.
Ball retainers: Cold-rolled, zinc-plated steel.
Balls: Hardened steel.

Telescopic ball bearing slides for applications in the industrial and electronics sector.

- Fast disconnection.
- Hold-in and hold-out.
- Can be mounted on either side.
- Cam drawer adjust (3.1 mm).
- Optional clip-on bracket (page 689).
- Service life 10,000 cycles.

Ordering details: e.g.: Prod. No. 649 018 30, Slides 3832 DO

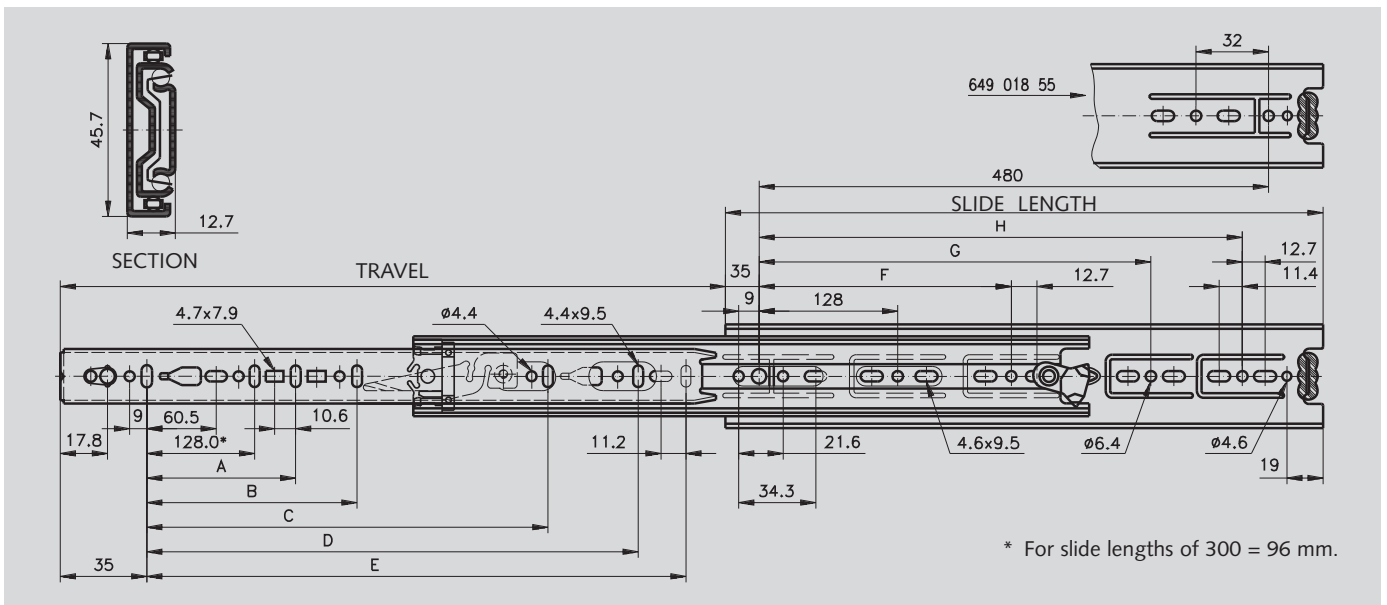
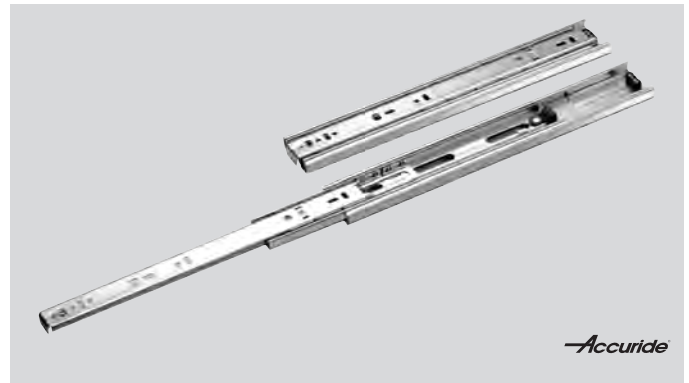

Product No. per Pair	Slide Length mm	Travel +/-3.2 mm	A mm	B mm	C mm	D mm	E mm	F mm	G mm	H mm	Load Rating per Pair kg	Weight per Pair kg
649 018 30	300	305	-	-	-	-	242	224	-	-	50	0.95
649 018 35	350	356	-	-	-	-	292	224	-	-	50	1.10
649 018 40	400	406	-	-	-	-	342	224	320	-	50	1.27
649 018 45	450	457	-	-	320	-	392	-	352	-	50	1.42
649 018 50	500	508	-	-	320	-	442	-	416	-	50	1.58
649 018 55	550	559	-	-	320	416	492	-	352	-	50	1.75
649 018 60	600	610	224	-	416	-	542	224	352	480	50	1.91
649 018 65	650	660	224	-	416	544	592	224	352	554	50	2.06
649 018 70	700	711	224	288	416	544	642	224	352	554	50	2.22

Note

Recommended mounts: M4 screw.
Use all mounting positions to achieve the max. load rating.
Horizontal mounting not recommended.

Optional Clip-On Brackets see page 689.

