

Pánty M233, plast, s nastaviteľným trením

Materiál: telo: Polyacetal (POM), RAL 9005, semi-matné
Os: Polykarbonat (PC).
Nastavovacia skrutka a matica: nerez 1.4305 (AISI 303).

Pri týchto nerozoberateľných pántoch, sa trenie nastavuje dotiahnutím skrutky.

Dlhodobé testy ukazujú že moment sa nemení ani pri 60.000 otvorení / zatvorení (0.8 Nm ťahovací moment sady skrutiek).

Teplotná odolnosť do +65°C.
Kategória horľavosti UL 94-HB.

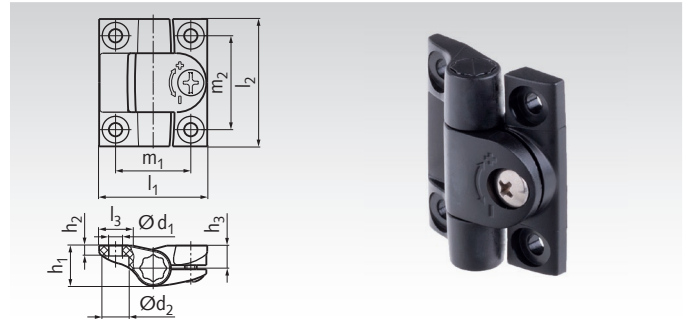

Informácie potrebné na objednanie: napr.: Produkt č. 677 002 81, Pánt M233, 37mm.

Produkt č.	l ₁ mm	l ₂ mm	d ₁ mm	M _A ¹⁾ Nm	d ₂ mm	h ₁ mm	h ₂ mm	h ₃ mm	l ₃ mm	m ₁ ^{±0,25} mm	m ₂ ^{±0,25} mm	max. trečí moment Nm	F _A ²⁾ N	F _R ³⁾ N	Hmotnosť g
677 002 81	37	43	4,5	1	9	14	3,5	7,5	11,5	25,5	31,7	1,4	700	500	15
677 002 82	57	64	6,5	3	12,5	21	6,5	11,5	17,5	38	47,5	4	1500	1500	49

¹⁾ Ťahovací moment pre skrutku d₁.

²⁾ Max. axiál sila. ³⁾ Max. radial sila pri otvorení o 90°. Toto sú orientačné hodnoty, bez garancie.

Pánty M237, odliate zo zinku / hlinníka / nerez.

Materiál: zliatina zinku (ZD), poplastované, čierna RAL 9005.
Hlinník, anodiz. v prírodzenej farbe.
Nerez 1.4308 (CF-8) matné.
Nerez 1.4408 (AISI 316) matné.
Os: Nerez 1.4571, AISI 316 Ti
(ZD: 1.4305, AISI 303)



Nerozoberateľné pánty. Rozsah otvorenia závisí na smere; 180° alebo 90° (typ C 180° alebo 70°).

Typ A: s dierami pre zápusťné skrutky DIN 7991.

Typ C: s závit. skrutkami

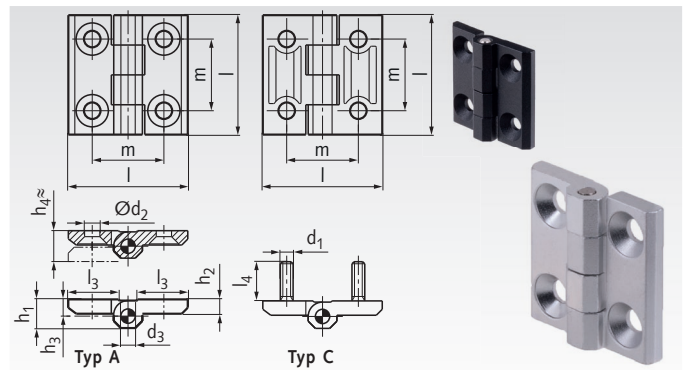

Informácie potrebné na objednanie: napr.: Produkt č. 677 003 01, Pánt M237, zinok, typ A, 30mm

Produkt č. Zinková zliatina	Produkt č. Hlinník, anodiz.	Typ	l mm	d ₁ mm	d ₂ mm	d ₃ mm	h ₁ mm	h ₂ mm	h ₃ mm	h ₄ ^{+0,5} mm	l ₃ mm	l ₄ mm	m mm	F _A ¹⁾ N	F _R ²⁾ N	Hmot. Zink g	Hmot. Alu g
677 003 01	677 003 21	A	30	-	4,3	3	7,5	4	4,5	8,5	10,7	-	18	500	750	19	11
677 003 02	677 003 22	A	40	-	5,3	4	9	5	5,5	11	14	-	25	1060	2000	46	24
677 003 03	677 003 23	A	50	-	6,4	6	11,5	6	6,5	13	18,5	-	30	2100	2450	89	48
677 003 04	677 003 24	A	60	-	8,3	8	15	8	8,5	17	21,5	-	36	3200	4400	163	90
677 003 05	-	C	40	M5	-	4	9	5	5,5	11	14	12	25	900	1850	59	-
677 003 06	-	C	50	M6	-	6	11,5	6	6,5	13	18,5	12	30	2050	2000	102	-
677 003 07	-	C	60	M8	-	8	15	8	8,5	17	21,5	14	36	3050	2550	194	-

¹⁾ Max. axiál sila. ²⁾ Max. radial sila pri otvorení o 90°. Toto sú orientačné hodnoty, bez garancie.



Produkt č. Nerez 1.4308	Produkt č. Nerez 1.4408	Typ	l mm	d ₁ mm	d ₂ mm	d ₃ mm	h ₁ mm	h ₂ mm	h ₃ mm	h ₄ ^{+0,5} mm	l ₃ mm	l ₄ mm	m mm	F _A ¹⁾ N	F _R ²⁾ N	Hmotnosť g
677 003 31	677 003 41	A	30	-	4,3	3	7,5	4	4,5	8,5	10,7	-	18	750	750	23
677 003 32	677 003 42	A	40	-	5,3	4	9	5	5,5	11	16	-	25	2100	1650	57
677 003 33	677 003 43	A	50	-	6,4	6	11,5	6	6,5	13	21	-	30	2550	2250	110
677 003 34	677 003 44	A	60	-	8,3	8	15	8	8,5	17	26	-	36	5000	5000	211
677 003 35	-	C	40	M5	-	4	9	5	5,5	11	16	11	25	?	?	69
677 003 36	-	C	50	M6	-	6	11,5	6	6,5	13	21	13	30	?	?	128
677 003 37	-	C	60	M8	-	8	15	8	8,5	17	26	17	36	?	?	200

¹⁾ Max. axiál sila. ²⁾ Max. radial sila pri otvorení o 90°. Toto sú orientačné hodnoty, bez garancie.