

## Presné nastavovacie a nivelizačné prvky

### Presné nivelizačné prvky MN 686.8 s guľovou plochou bez poist. matice

Materiál:

Štandardná verzia: 42CrMo4V, č. 1.7225, pozinkovaný, pasivovaný na modro.

Nerezová verzia: 1.4301 (AISI 304).



- Pre nerovnoběžné povrchy, sklon až do 4°.
- Väčšia celková výška a väčšia dráha nastavovania.
- Bez poistnej matice.

Informácie potrebné na objednanie: napr.: Produkt č. 686 805 00, MN 686.8 15-6.6 štandard

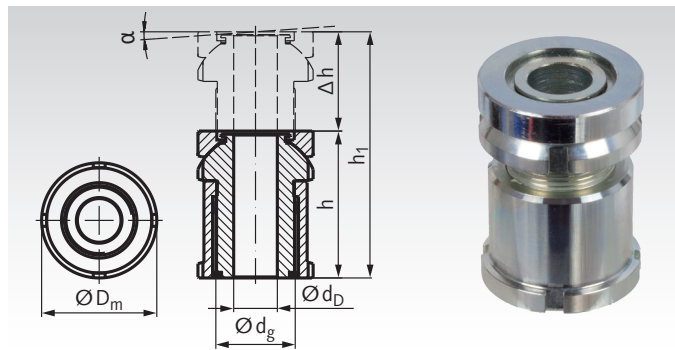

Produkt č. štandard	Produkt č. nerez	Typ	vhodná skrutka	h mm	h1 mm	Δh mm	D <sub>m</sub> mm	d <sub>g</sub> mm	d <sub>D</sub> mm	α cca	F <sub>tot.</sub> * kN	F <sub>add.</sub> * kN	Hmot. g
686 805 00	686 998 05	MN 686.8 15-6,6	M6	35	50	15	25	M15x1,0	6,6	4°	40	30,7	98
686 810 00	686 998 10	MN 686.8 20-6,6	M6	43	63	20	32	M20x1,0	6,6	4°	65	55,7	197
686 815 00	686 998 15	MN 686.8 20-9,0	M8	43	63	20	32	M20x1,0	9,0	4°	65	48,0	187
686 820 00	686 998 20	MN 686.8 20-11,0	M10	43	63	20	32	M20x1,0	11,0	4°	65	37,9	175
686 825 00	686 998 25	MN 686.8 30-11,0	M10	54	79	25	45	M30x1,5	11,0	4°	120	92,9	484
686 830 00	686 998 30	MN 686.8 30-13,5	M12	54	79	25	45	M30x1,5	13,5	4°	120	80,4	464
686 835 00	686 998 35	MN 686.8 30-17,5	M16	54	79	25	45	M30x1,5	17,5	4°	120	45,5	428
686 840 00	686 998 40	MN 686.8 40-17,5	M16	70	102	32	58	M40x1,5	17,5	4°	210	136,0	1037
686 845 00	686 998 45	MN 686.8 40-22,0	M20	70	102	32	58	M40x1,5	22,0	4°	210	90,0	959
686 850 00	686 998 50	MN 686.8 40-26,0	M24	70	102	32	58	M40x1,5	26,0	4°	210	37,0	878
686 855 00	686 998 55	MN 686.8 50-22,0	M20	83	123	40	70	M50x1,5	22,0	4°	330	210,0	1838
686 860 00	686 998 60	MN 686.8 50-26,0	M24	83	123	40	70	M50x1,5	26,0	4°	330	157,0	1742
686 865 00	686 998 65	MN 686.8 50-33,0	M30	83	123	40	70	M50x1,5	33,0	4°	330	53,0	1528
686 870 00	686 998 70	MN 686.8 60-26,0	M24	94	144	50	80	M60x2,0	26,0	4°	495	322,0	2585
686 875 00	686 998 75	MN 686.8 60-33,0	M30	94	144	50	80	M60x2,0	33,0	4°	495	218,0	2351
686 880 00	686 998 80	MN 686.8 60-39,0	M36	94	144	50	80	M60x2,0	39,0	4°	495	101,0	2115

Iné veľkosti na žiadosť.

### Presné nivelizačné prvky MN 686.9 s guľovou plochou s poist. maticou

Materiál:

Štandardná verzia: 42CrMo4V, č. 1.7225, pozinkovaný, pasivovaný na modro.

Nerezová verzia: 1.4301 (AISI 304).



- Pre nerovnoběžné povrchy, sklon až do 4°.
- Väčšia celková výška a väčšia dráha nastavovania.
- S poistnou maticou.

Informácie potrebné na objednanie: napr.: Produkt č. 686 905 00, MN 686.9 15-6.6 štandard

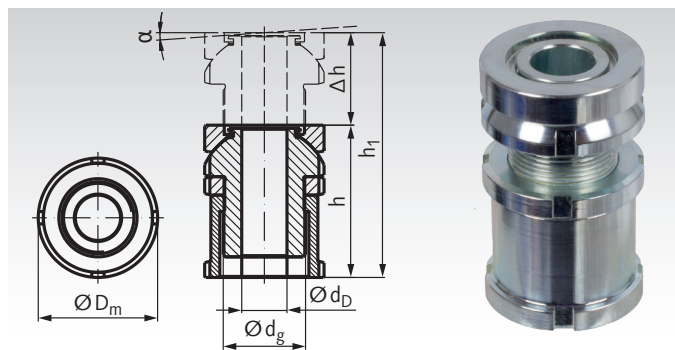

Produkt č. štandard	Produkt č. nerez	Typ	vhodná skrutka	h mm	h1 mm	Δh mm	D <sub>m</sub> mm	d <sub>g</sub> mm	d <sub>D</sub> mm	α cca	F <sub>tot.</sub> * kN	F <sub>add.</sub> * kN	Hmot. g
686 905 00	686 999 05	MN 686.9 15-6,6	M6	40	50	10	25	M15x1,0	6,6	4°	40	30,7	98
686 910 00	686 999 10	MN 686.9 20-6,6	M6	49	63	14	32	M20x1,0	6,6	4°	65	55,7	215
686 915 00	686 999 15	MN 686.9 20-9,0	M8	49	63	14	32	M20x1,0	9,0	4°	65	48,0	205
686 920 00	686 999 20	MN 686.9 20-11,0	M10	49	63	14	32	M20x1,0	11,0	4°	65	37,9	193
686 925 00	686 999 25	MN 686.9 30-11,0	M10	61	79	18	45	M30x1,5	11,0	4°	120	92,9	523
686 930 00	686 999 30	MN 686.9 30-13,5	M12	61	79	18	45	M30x1,5	13,5	4°	120	80,4	502
686 935 00	686 999 35	MN 686.9 30-17,5	M16	61	79	18	45	M30x1,5	17,5	4°	120	45,5	462
686 940 00	686 999 40	MN 686.9 40-17,5	M16	79	102	23	58	M40x1,5	17,5	4°	210	136,0	1106
686 945 00	686 999 45	MN 686.9 40-22,0	M20	79	102	23	58	M40x1,5	22,0	4°	210	90,0	1027
686 950 00	686 999 50	MN 686.9 40-26,0	M24	79	102	23	58	M40x1,5	26,0	4°	210	37,0	959
686 955 00	686 999 55	MN 686.9 50-22,0	M20	94	123	29	70	M50x1,5	22,0	4°	330	210,0	1978
686 960 00	686 999 60	MN 686.9 50-26,0	M24	94	123	29	70	M50x1,5	26,0	4°	330	157,0	1882
686 965 00	686 999 65	MN 686.9 50-33,0	M30	94	123	29	70	M50x1,5	33,0	4°	330	53,0	1666
686 970 00	686 999 70	MN 686.9 60-26,0	M24	105	144	39	80	M60x2,0	26,0	4°	495	322,0	2747
686 975 00	686 999 75	MN 686.9 60-33,0	M30	105	144	39	80	M60x2,0	33,0	4°	495	218,0	2508
686 980 00	686 999 80	MN 686.9 60-39,0	M36	105	144	39	80	M60x2,0	39,0	4°	495	101,0	2280

Iné veľkosti na žiadosť.

\* Hodnoty sa vzťahujú na štandardnú oceľ.verziu. Hodnoty pre nerezovú verziu, strana 607.  
F<sub>tot.</sub> = max. zataženie. (vrátane predpätia každej upevňovacej skrutky).  
F<sub>add.</sub> = Zataženie po odrátaní predpätia každej upevňovacej skrutky.