

Curved-Tooth Gear Couplings BW, Polyamide 6.6

Bore tolerance + 0.05/-0.10 mm
with feather keyways according to
DIN 6885/1 ±0.08 mm.

Grub Screws, Stainless steel V4A.

Largest axial displacement = max. ±1 mm.

Largest angular displacement = max. ±1°.

No radial displacement. The permissible
displacement values are dependent on
power and speed.

Max. speed: 6000 min⁻¹

Both parts have to be ordered separately.

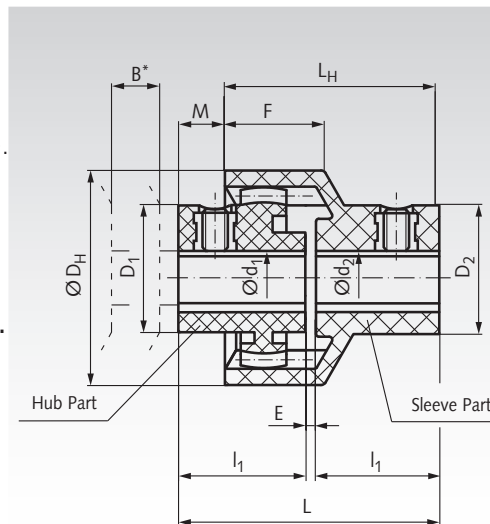

Hub mould:

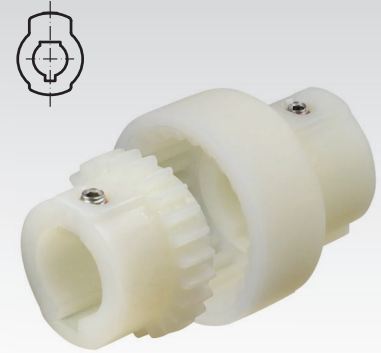

Ordering Details: e.g.:

1 Item Coupling BW, Bore $d_1 = 6$, $d_2 = 10$ mm:

1 Item Product No. 60700600 Hub Part

1 Item Product No. 60611000 Sleeve Part

Product No. Hub	Size	d_1 mm	D_1 mm	Product No. Sleeve	d_2 mm	D_2 mm	Torque normal Nm	Torque peak Nm	D_H mm	B^* mm	l_1 mm	E mm	L mm	L_H mm	M mm	F mm	Weight Hub g	Weight Sleeve g
607 006 00	14	6	21	-	-	-	5	10	40	15	23	2	48	40	8	18,5	13,5	-
607 007 00	14	7	21	-	-	-	5	10	40	15	23	2	48	40	8	18,5	13,5	-
607 008 00	14	8	21	-	-	-	5	10	40	15	23	2	48	40	8	18,5	13,5	-
607 009 00	14	9	21	-	-	-	5	10	40	15	23	2	48	40	8	18,5	13,5	-
607 010 00	14	10	23	606 110 00	10	24	5	10	40	15	23	2	48	40	8	18,5	13,5	28
607 011 00	14	11	23	606 111 00	11	24	5	10	40	15	23	2	48	40	8	18,5	13,5	28
607 012 00	14	12	26	606 112 00	12	26	5	10	40	15	23	2	48	40	8	18,5	13,5	28
607 014 00	14	14	26	606 114 00	14	26	5	10	40	15	23	2	48	40	8	18,5	13,5	28
607 212 00	19	12	27	-	-	-	8	16	47	16	25	2	52	42	10	19,0	15,5	-
607 214 00	19	14	27	606 314 00	14	28,5	8	16	47	16	25	2	52	42	10	19,0	15,5	32
607 216 00	19	16	29	606 315 00	15	28,5	8	16	47	16	25	2	52	42	10	19,0	15,5	32
607 219 00	19	19	32	606 319 00	19	33	8	16	47	16	25	2	52	42	10	19,0	15,5	32
607 410 00	24	10	25,5	-	-	-	12	24	53	17	26	2	54	45	9	21,5	25	-
607 411 00	24	11	25,5	-	-	-	12	24	53	17	26	2	54	45	9	21,5	25	-
607 412 00	24	12	25,5	-	-	-	12	24	53	17	26	2	54	45	9	21,5	25	-
607 414 00	24	14	30	606 514 00	14	30	12	24	53	17	26	2	54	45	9	21,5	25	45
607 415 00	24	15	30	-	-	-	12	24	53	17	26	2	54	45	9	21,5	25	-
607 416 00	24	16	30	-	-	-	12	24	53	17	26	2	54	45	9	21,5	25	-
607 418 00	24	18	34,5	-	-	-	12	24	53	17	26	2	54	45	9	21,5	25	-
607 419 00	24	19	34,5	606 519 00	19	34,5	12	24	53	17	26	2	54	45	9	21,5	25	45
607 420 00	24	20	34,5	606 520 00	20	34,5	12	24	53	17	26	2	54	45	9	21,5	25	45
607 424 00	24	24	37,5	606 524 00	24	39	12	24	53	17	26	2	54	45	9	21,5	25	45

* B is the minimum dimension by which a machine part has to be moved in order to demount one of the coupled units in vertical direction.

General

All parts of the couplings are made from plastic (polyamide). This means large wear resistance and excellent resistance to oils, fats, grease, fuels, alcohols, esters, ketones, and grachatic hydrocarbons. But concentrated mineral acids, formic acid, kresol, glycol and benzyl alcohol can - especially at higher temperatures - dissolve polyamide 6.6. The plastics are resistant to condensation and splash water. Operating temperature -25°C to +100°C.

The torque of the couplings is transmitted from the first hub with the tothing via the sleeve part with straight inner tothing onto the second hub. Horizontal as well as vertical shaft connection is possible. The curved-tooth gear couplings BW compensate angular and axial misalignment of the shafts.

When running the coupling in, the outer layer of the plastic teeth is worn away. The resulting flocculent abrasion is not to be interpreted as wear. Simple mounting - no maintenance - low weight - long service life.

Mounting

Align shafts, put feather keys into the keyways, push hub and sleeve part onto the shaft. The set screws can be entered. Now the hub part is pushed that far into the sleeve part, that a gap of 2mm remains between the shaft ends. Then the set screws M5 have to be tightened. Fastening torque 1.4 Nm.