

Planetary Gear MPS

The lightweight, low-noise and low-backlash planetary gearheads are available in 24 ratios. They are characterized by their high power density, running smoothness and overload capacity. The 3 housing sizes \varnothing 40 mm, 60 mm and 80 mm fit to many applications.

- Lubrication: Fluid grease, lubricated for life.
- Any mounting position possible.
- Temperature range: -25°C to $+90^{\circ}\text{C}$.

The selection of the suitable motor depends on the application. The use of a stepper motor or servo motor is common. But other motor types can also be used.

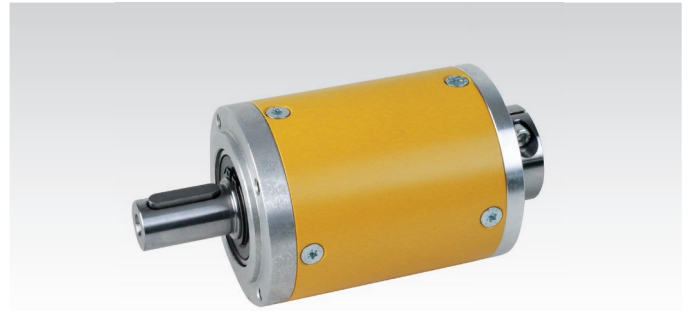

Ordering Details: e.g.: Product No. 40514004, Planetary Gear MPS 40, Ratio 4:1

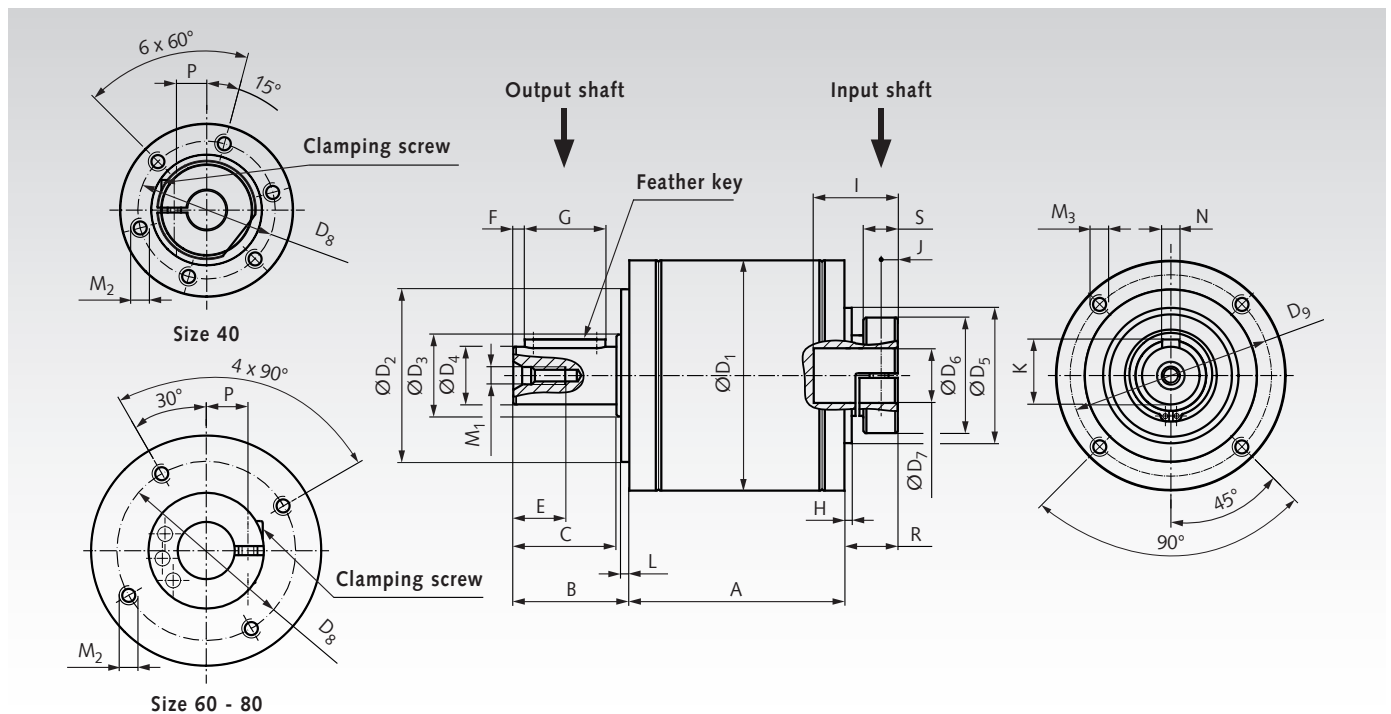

Size	Number of gear stages	A mm	Radial force* F_R N	Axial force* F_A N	Clamping screw ISO 4762 - 8.8 mm	Width across flats SW mm	Fastening torque T_A Nm	Feather key DIN 6885 mm	Weight kg
40	1	45,5	200	200	M3 x 10	2,5	1,3	A3 x 3 x 18	0,3
	2	67							0,4
60	1	58	400	500	M4 x 12	3	3	A5 x 5 x 25	0,9
	2	83							1,2
	3	108							1,6
80	1	75	750	1000	M5 x 16	4	6	A6 x 6 x 28	1,9
	2	104							2,6
	3	133							3,4

* The max. radial and axial forces refer to the middle of the output shaft and output speed 100 min^{-1} .

Size	B mm	C mm	D_1 mm	D_2^{h7} mm	D_3 mm	D_4^{h7} mm	D_5^{h6} mm	D_6 mm	D_7^{F7} mm	D_8 mm	D_9 mm	E mm	F mm
40	26	23	40	26*	12	10	24	22	9	31	34	10	2,5
60	35	30	60	40	17	14	37	30	14	48	52	12,5	2,5
80	40	36	80	60	25	20	47	40	19	62	70	16	4,0
Size	G mm	H mm	I mm	J mm	K mm	L mm	M_1 mm	M_2 mm	M_3 mm	N^{h9} mm	P mm	R mm	S mm
40	18	1,0	17	4	11,2	2	M4	M3 x 7	M4 x 6	3	7	12	8,3
60	25	1,75	20	5,5	16	3	M5	M4 x 9	M5 x 8	5	10,5	16,75	11,0
80	28	2,5	27	6,5	22,5	3	M6	M5 x 9	M6 x 11	6	14,5	18,50	13,0

* Dimension $D_2 = 26 \text{ mm}$, Tolerance h6

Planetary Gear MPS, Performance Data

i = transmission ratio.
 n_{1N} [min^{-1}] = nominal input speed.
 $n_{1\text{max}}$ [min^{-1}] = max. input speed.
 n_2 [min^{-1}] = output speed.
 $T_{2\text{zul}}$ [Nm] = permissible output torque (continuous operation).
 $T_{a\text{max}}$ [Nm] = max. acceleration torque at the output.
 $T_{2\text{max}}$ [Nm] = max. output torque.
 φ [arcmin] = backlash.
 η [%] = operating efficiency.
 C_t [Nm/arcmin] = torsional stiffness.
 J [kgcm^2] = mass moment of inertia.

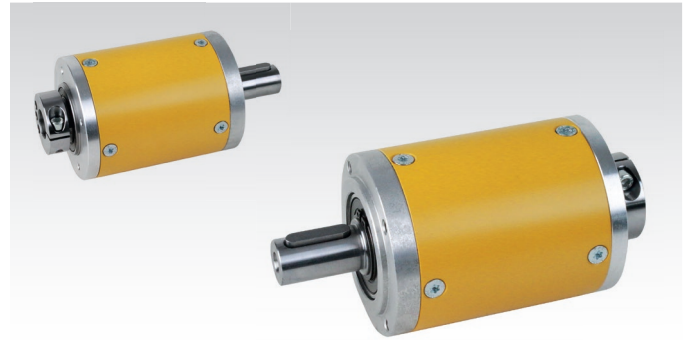

Motor adaption and reducing bush have to be ordered separately, see page 894.

Special versions on request.

Size	Product No.	Ratio i	Gear- stages	n_{1N} min^{-1}	$n_{1\text{max}}$ min^{-1}	T_1 Nm	$T_{2\text{zul}}^{1)}$ Nm	$T_{a\text{max}}^{2)}$ Nm	$T_{2\text{max}}^{3)}$ Nm	φ arcmin	η %	C_t Nm/arcmin	$J^{4)}$ kgcm^2
40	405 140 04	4 : 1	1	4500	8000	4,12	16	25	36	≤ 15	> 97	1,0	0,022
40	405 140 05	5 : 1	1	4500	8000	2,89	14	23	34	≤ 15	> 97	1,0	0,019
40	405 140 07	7 : 1	1	4500	8000	2,06	14	23	34	≤ 15	> 97	1,0	0,018
40	405 140 08	8 : 1	1	4500	8000	1,80	14	23	34	≤ 15	> 97	1,0	0,017
40	405 140 16	16 : 1	2	4500	8000	1,06	16	25	36	≤ 19	> 94	1,1	0,022
40	405 140 20	20 : 1	2	4500	8000	0,85	16	25	36	≤ 19	> 94	1,1	0,019
40	405 140 25	25 : 1	2	4500	8000	0,60	14	23	34	≤ 19	> 94	1,1	0,019
40	405 140 28	28 : 1	2	4500	8000	0,61	16	25	36	≤ 19	> 94	1,1	0,017
40	405 140 32	32 : 1	2	4500	8000	0,53	16	25	36	≤ 19	> 94	1,1	0,017
40	405 140 35	35 : 1	2	4500	8000	0,43	14	23	34	≤ 19	> 94	1,1	0,017
40	405 140 40	40 : 1	2	4500	8000	0,37	14	23	34	≤ 19	> 94	1,1	0,016
40	405 140 49	49 : 1	2	4500	8000	0,30	14	23	34	≤ 19	> 94	1,1	0,018
40	405 140 56	56 : 1	2	4500	8000	0,27	14	23	34	≤ 19	> 94	1,1	0,017
40	405 140 64	64 : 1	2	4500	8000	0,23	14	23	34	≤ 19	> 94	1,1	0,016
60	405 160 03	3 : 1	1	3000	6000	10,31	30	60	80	≤ 10	> 97	1,5	0,17
60	405 160 04	4 : 1	1	3000	6000	10,05	39	68	88	≤ 10	> 97	1,5	0,13
60	405 160 05	5 : 1	1	3000	6000	5,77	28	56	74	≤ 10	> 97	1,5	0,11
60	405 160 07	7 : 1	1	3000	6000	3,83	26	52	70	≤ 10	> 97	1,5	0,1
60	405 160 08	8 : 1	1	3000	6000	3,48	27	54	72	≤ 10	> 97	1,5	0,1
60	405 160 12	12 : 1	2	3000	6000	2,66	30	60	80	≤ 12	> 94	1,5	0,17
60	405 160 15	15 : 1	2	3000	6000	2,13	30	60	80	≤ 12	> 94	1,5	0,11
60	405 160 16	16 : 1	2	3000	6000	2,59	39	68	88	≤ 12	> 94	1,5	0,13
60	405 160 20	20 : 1	2	3000	6000	2,07	39	68	88	≤ 12	> 94	1,5	0,11
60	405 160 25	25 : 1	2	3000	6000	1,19	28	56	74	≤ 12	> 94	1,5	0,11
60	405 160 32	32 : 1	2	3000	6000	1,30	39	68	88	≤ 12	> 94	1,5	0,1
60	405 160 40	40 : 1	2	3000	6000	0,74	28	56	74	≤ 12	> 94	1,5	0,1
60	405 160 49	49 : 1	2	3000	6000	0,56	26	52	70	≤ 12	> 94	1,5	0,1
60	405 160 56	56 : 1	2	3000	6000	0,49	26	52	70	≤ 12	> 94	1,5	0,1
60	405 160 64	64 : 1	2	3000	6000	0,45	27	54	72	≤ 12	> 94	1,5	0,1
60	405 160 80	80 : 1	3	3000	6000	0,54	39	68	88	≤ 15	> 91	1,5	0,11
60	405 161 00	100 : 1	3	3000	6000	0,43	39	68	88	≤ 15	> 91	1,5	0,11
60	405 161 25	125 : 1	3	3000	6000	0,25	28	56	74	≤ 15	> 91	1,5	0,11
60	405 161 60	160 : 1	3	3000	6000	0,27	39	68	88	≤ 15	> 91	1,5	0,1
60	405 162 00	200 : 1	3	3000	6000	0,15	28	56	74	≤ 15	> 91	1,5	0,1
60	405 162 56	256 : 1	3	3000	6000	0,17	39	68	88	≤ 15	> 91	1,5	0,1
60	405 165 12	512 : 1	3	3000	6000	0,06	27	54	72	≤ 15	> 91	1,5	0,1
80	405 180 03	3 : 1	1	3500	6000	24,05	70	140	190	≤ 7	> 97	5,8	0,7
80	405 180 04	4 : 1	1	3500	6000	23,71	92	184	236	≤ 7	> 97	6,0	0,53
80	405 180 05	5 : 1	1	3500	6000	13,81	67	134	181	≤ 7	> 97	5,6	0,44
80	405 180 07	7 : 1	1	3500	6000	9,57	65	130	175	≤ 7	> 97	5,5	0,39
80	405 180 08	8 : 1	1	3500	6000	8,25	64	128	172	≤ 7	> 97	5,5	0,37
80	405 180 12	12 : 1	2	3500	6000	6,21	70	140	190	≤ 9	> 94	6,0	0,7
80	405 180 15	15 : 1	2	3500	6000	4,96	70	140	190	≤ 9	> 94	5,8	0,45
80	405 180 16	16 : 1	2	3500	6000	6,12	92	184	236	≤ 9	> 94	6,0	0,53
80	405 180 20	20 : 1	2	3500	6000	4,89	92	184	236	≤ 9	> 94	6,0	0,44
80	405 180 25	25 : 1	2	3500	6000	2,85	67	134	181	≤ 9	> 94	5,6	0,44
80	405 180 32	32 : 1	2	3500	6000	3,06	92	184	236	≤ 9	> 94	6,0	0,37
80	405 180 40	40 : 1	2	3500	6000	1,78	67	134	181	≤ 9	> 94	5,6	0,37
80	405 180 49	49 : 1	2	3500	6000	1,41	65	130	175	≤ 9	> 94	5,5	0,39
80	405 180 56	56 : 1	2	3500	6000	1,23	65	130	175	≤ 9	> 94	5,5	0,39
80	405 180 64	64 : 1	2	3500	6000	1,06	64	128	172	≤ 9	> 94	5,5	0,37
80	405 180 80	80 : 1	3	3500	6000	1,26	92	184	236	≤ 11	> 91	6,0	0,45
80	405 181 00	100 : 1	3	3500	6000	1,01	92	184	236	≤ 11	> 91	6,0	0,44
80	405 181 25	125 : 1	3	3500	6000	0,59	67	134	181	≤ 11	> 91	5,6	0,44
80	405 181 60	160 : 1	3	3500	6000	0,63	92	184	236	≤ 11	> 91	6,0	0,37
80	405 182 00	200 : 1	3	3500	6000	0,37	67	134	181	≤ 11	> 91	5,6	0,37
80	405 182 56	256 : 1	3	3500	6000	0,39	92	184	236	≤ 11	> 91	6,0	0,37
80	405 185 12	512 : 1	3	3500	6000	0,14	64	128	172	≤ 11	> 91	5,5	0,37

¹⁾ Lifetime 20,000 h at output speed 100 min^{-1} .

²⁾ max. 1,000 Cycles per hr. $T_{a\text{max}}$ - Share < 5% of total running time.

³⁾ max. 1,000 cycles during the gearbox service life.

⁴⁾ related to the drive shaft.

Motor Adaptations for Planetary Gears MPS and MPL

Version for motor model B5

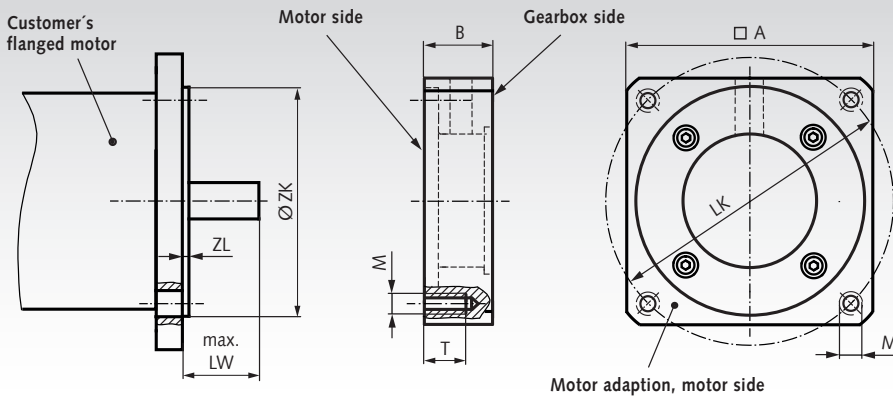

Motor adaption, motor side

Product No.	suitable for	A mm	B mm	LK mm	LW mm	M mm	T mm	ZK mm	ZL mm	Weight g
405 340 40	MPS 40	55	18	63	23	M5	12	40	2,8	90
405 340 60	MPS 40	70	25	75	30	M5	18	60	3,5	220
405 360 40	MPS 60	60	20	63	23	M5	14	40	2,8	130
405 360 60	MPS 60	70	27	75	30	M5	16	60	3,5	250
405 360 70	MPS 60	80	37	90	40	M6	19	70	3,5	490
405 360 80	MPS 60	90	27	100	30	M6	19	80	3,5	450
405 380 60	MPS 80	80	23	75	30	M5	16	60	3,5	250
405 380 70	MPS 80	80	33	90	40	M6	19	70	3,5	380
405 380 80	MPS 80	90	23	100	30	M6	16	80	3,5	340
405 381 80	MPS 80	90	33	100	40	M6	20	80	3,5	510
405 380 95	MPS 80	100	33	115	40	M8	25	95	3,5	650

Product No.	suitable for	A mm	B mm	LK mm	LW mm	M mm	T mm	ZK mm	ZL mm	Weight g
405 450 40	MPL 50	55	17	63	20	M5	13	40	2,8	90
405 450 60	MPL 50	70	27	75	30	M5	19	60	3,5	250
405 470 40*	MPL 70	Ø73	17,5	63	23	M5	13	40	2,8	120
405 470 60	MPL 70	70	21,5	75	30	M5	15	60	3,5	170
405 470 70	MPL 70	80	31,5	90	40	M6	20	70	3,5	380
405 470 80	MPL 70	90	21,5	100	30	M6	**	80	3,5	320
405 490 60*	MPL 90	Ø93	21	75	30	M5	16	60	3,5	200
405 490 70	MPL 90	90	27	90	40	M6	20	70	3,5	340
405 490 80	MPL 90	90	27	100	30	M6	20	80	3,5	330
405 490 95	MPL 90	100	27	115	40	M8	22	95	3,5	440

The four fastening screws for mounting the flange to the gearbox are included in the scope of delivery. Other flange versions, such as design B14 (2-piece) and also for IEC motors, are available on request.

* This motor adaptation is round.

** This threadhole is a through-hole.

Ordering Details: e.g.: Product No. 40534040, Motor Adaption MPS 40, LK 63 mm, M5, ZK 40 mm

Reducing Bushes for Planetary Gears MPS and MPL

Motor adaption Reducing bush Gear with shaft collar

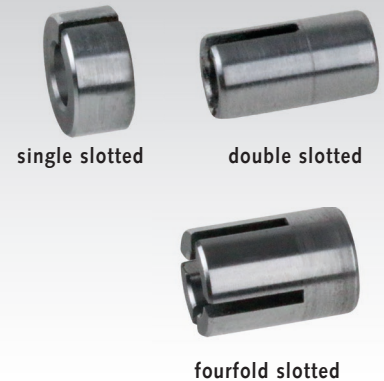
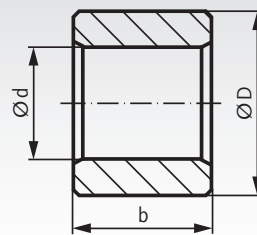
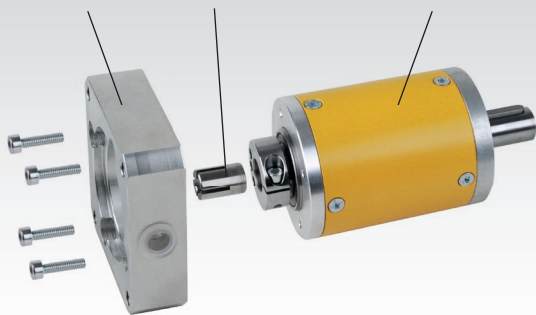

Product No.	suitable for	d mm	D mm	b mm	Weight g
405 540 06	MPS 40	6	9	17	4
405 560 09	MPS 60	9	14	20	12
405 560 11	MPS 60	11	14	20	8
405 580 11	MPS 80	11	19	25	32
405 580 14	MPS 80	14	19	25	24

Product No.	suitable for	d mm	D mm	b mm	Weight g
405 650 08	MPL 50	8	18	9	14
405 650 09	MPL 50	9	18	9	12
405 650 11	MPL 50	11	18	9	11
405 650 12	MPL 50	12	18	9	10
405 650 14	MPL 50	14	18	9	7
405 670 09	MPL 70	9	19	13,5	21
405 670 10	MPL 70	10	19	13,5	21
405 670 11	MPL 70	11	19	13,5	19
405 670 14	MPL 70	14	19	13,5	13
405 670 16	MPL 70	16	19	13,5	9
405 690 11	MPL 90	11	28	20	79
405 690 14	MPL 90	14	28	20	70
405 690 16	MPL 90	16	28	20	63
405 690 19	MPL 90	19	28	20	50
405 690 24	MPL 90	24	28	20	24

Reducing bushes for adapting motor with divergent shaft diameters. Depending on the type and size, the bushings are slotted 1-fold, 2-fold or 4-fold. Please refer to the assembly instructions at www.maedler.de

Ordering Details: e.g.: Product No. 40554006, Reducing Bush MPS 40, 6 x 9 x 17 mm