

## Locking Assemblies COM-L, QPQ-Coated

**Material:** Steel.

- For fixing a hub (e.g. drive wheel, rotor or similar) on a shaft.
- **QPQ coated:** High corrosion resistance, improved fatigue strength, primarily food safe (further information see below).
- For very high torques.
- Self-centering.
- Slight axial offset possible during assembly.

**Concentricity:** 0.02 to 0.04 mm.

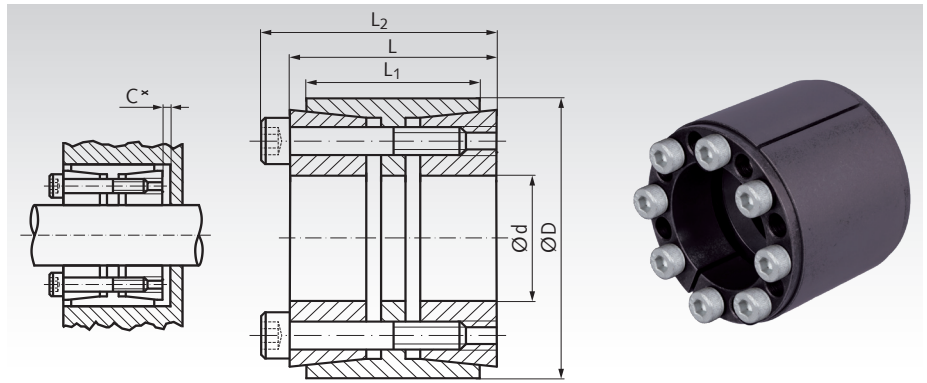

Ordering Details: e.g.: Product No. 615 511 25Q, Locking Assembly COM-L QPQ, 25 mm

Product No.	d mm	D mm	L <sub>1</sub> mm	L mm	C* mm	L <sub>2</sub> mm	at T <sub>A</sub> transmittable		Surface Pressure		Screws** DIN 912 12.9	Weight	
							T Nm	F <sub>ax</sub> kN	P <sub>w</sub> N/mm <sup>2</sup>	P <sub>N</sub> N/mm <sup>2</sup>			Number x Size
615 511 25Q	25	55	32	40	4	46	810	65	288	98	6 x M6 x 35	17	0,35
615 511 28Q	28	55	32	40	4	46	950	65	268	102	6 x M6 x 35	17	0,42
615 511 30Q	30	55	32	40	4	46	970	68	241	98	6 x M6 x 35	17	0,40
615 511 35Q	35	60	44	54	5	60	1240	70	157	83	7 x M6 x 45	17	0,60
615 511 38Q	38	75	44	54	5	62	2780	145	263	117	7 x M8 x 50	41	1,15
615 511 40Q	40	75	44	54	5	62	3020	146	293	121	7 x M8 x 50	41	0,59
615 511 42Q	42	75	44	54	5	62	3150	151	248	116	7 x M8 x 50	41	1,25
615 511 45Q	45	75	44	54	5	62	3390	151	261	121	7 x M8 x 50	41	0,74
615 511 48Q	48	80	56	64	4	72	3920	159	161	96	8 x M8 x 55	41	1,30
615 511 50Q	50	80	56	64	4	72	4110	163	156	97	8 x M8 x 55	41	1,26
615 511 55Q	55	85	56	64	4	72	4370	164	137	89	8 x M8 x 55	41	1,36
615 511 60Q	60	90	56	64	4	72	6320	211	167	111	10 x M8 x 55	41	1,46
615 511 65Q	65	95	56	64	4	72	7100	217	160	109	10 x M8 x 55	41	1,55
615 511 70Q	70	110	70	78	4	88	11730	314	184	117	10 x M10 x 60	83	2,9
615 511 75Q	75	115	70	78	5	88	11900	340	159	104	10 x M10 x 60	83	3,0
615 511 80Q	80	120	70	78	5	88	16400	392	196	130	12 x M10 x 60	83	3,3
615 511 85Q	85	125	70	78	5	88	16600	400	175	119	12 x M10 x 60	83	3,4
615 511 90Q	90	130	70	78	5	88	18000	400	169	116	12 x M10 x 60	83	3,5
615 511 95Q	95	135	70	78	5	88	19000	412	160	112	12 x M10 x 60	83	3,7
615 512 00Q	100	145	90	100	6	112	27900	559	165	113	12 x M12 x 80	145	5,5

\* When using in a stepped bore, the clearance C is to be foreseen for demounting.

\*\* Screws with special coating.

T = transmittable torque at F<sub>ax</sub> = 0.  
 F<sub>ax</sub> = transmittable axial force at T = 0.  
 P<sub>w</sub> = surface pressure onto the shaft.  
 P<sub>N</sub> = surface pressure onto the hub.  
 T<sub>A</sub> = fastening torque of the screws.

More sizes up to d=300mm for 444,000Nm are available.  
 Price and delivery time on request.

### What is QPQ Nitro Carburising?

- Q = Quench (nitrocarburising followed by oxidising cooling process).  
 P = Polish (mechanical polishing up to desired surface finish before nitrocarburising).  
 Q = Quench (Oxidising to increase the corrosion resistance).  
 Salt-bath nitro carburising is, in many cases, a good alternative to other surface layer treatments as case hardening or hard plating.

### QPQ Surface Properties

Very good corrosion resistance, better than hard chrome or chem. nickel. Corrosion resistance in the salt spray test SS CASS in accordance with DIN 50021.  
 Improved wear resistance, no fretting corrosion, no cold shut.  
 Increased endurance strength, sometimes up to 100% higher.  
 Is completely safe to use with food as long as there is no contact with any acidic substances with a pH-value of ≤ 4.

### Fit

Shaft h8, Hub H8.  
 Surface roughness hub/shaft R<sub>z</sub> max. 12.5 µm.

### Mounting

Slightly oil the locking assembly before mounting, do not use MoS2 or grease. Tighten the screws evenly and crosswise in several steps to the set torque. To ease mounting the outer ring and the rear tensioning ring can be fixed with screws via the forcing thread.

### Demounting

Remove all tensioning screws and screw them into the unused forcing threads of the front tensioning ring, until it is released. Then screw in the screws into the unused forcing threads of the outer ring, until the rear tensioning ring is released.