

## Spur Gears made from POM, Black, wide Version, with One-Sided Hub, Straight Tooth System, Milled Teeth

Tooth quality 10d25 DIN 3967.  
 Pressure angle 20°.  
 Untoleranced dimensions in accordance with DIN ISO 2768 m.  
 Temperature limit: continuous 100°C, only short time 140°C.  
 Water absorption (satiated) 0.5% Cws.  
 Other material reference values page 864.

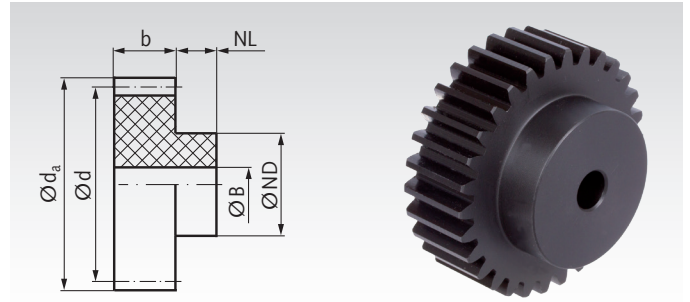

Order. Details: e.g.: Product No. 297 110 10, Spur Gear, POM black, Module 2.5, 10 Teeth

### Module 2.5 Tooth Width b = 25 mm

Product No.	Number of teeth	b mm	da mm	d mm	NL mm	ND mm	B <sup>JS10</sup> mm	perm. MT* Nm	Weight g
297 110 10	10	25	30	25	15	20	8	1,54	20,0
297 110 12	12	25	35	30	15	20	8	2,14	27,5
297 110 15	15	25	42,5	37,5	15	25	8	3,20	44,9
297 110 16	16	25	45	40	15	30	8	3,56	55,0
297 110 18	18	25	50	45	15	35	8	4,25	71,5
297 110 20	20	25	55	50	15	35	12	5,56	81,7
297 110 24	24	25	65	60	15	40	12	8,75	118
297 110 25	25	25	67,5	62,5	15	45	12	9,63	133
297 110 30	30	25	80	75	15	50	12	15,0	187
297 110 36	36	25	95	90	15	60	12	24,0	273
297 110 40	40	25	105	100	15	70	12	29,9	346
297 110 45	45	25	117,5	112,5	15	70	15	34,5	414
297 110 50	50	25	130	125	15	80	15	38,8	519
297 110 60	60	25	155	150	15	90	15	46,8	734

### Module 3 Tooth Width b = 30 mm

Product No.	Number of teeth	b mm	da mm	d mm	NL mm	ND mm	B <sup>JS10</sup> mm	perm. MT* Nm	Weight g
298 110 10	10	30	36	30	20	25	12	2,76	35,1
298 110 12	12	30	42	36	20	25	12	3,84	48,0
298 110 14	14	30	48	42	20	30	12	5,04	79,0
298 110 15	15	30	51	45	20	35	12	5,76	84,9
298 110 18	18	30	60	54	20	45	12	7,74	131
298 110 20	20	30	66	60	20	45	12	10,1	154
298 110 24	24	30	78	72	20	50	12	15,8	216
298 110 25	25	30	81	75	20	60	14	17,5	251
298 110 28	28	30	90	84	20	60	14	23,0	300
298 110 30	30	30	96	90	20	60	14	27,2	332
298 110 35	35	30	111	105	20	80	14	42,0	489
298 110 36	36	30	114	108	20	80	14	45,0	509
298 110 40	40	30	126	120	20	80	14	52,4	599
298 110 45	45	30	141	135	20	90	20	59,5	749
298 110 48	48	30	150	144	20	95	20	63,8	880
298 110 50	50	30	156	150	20	100	20	66,7	930
298 110 60	60	30	186	180	20	100	20	81,0	1253

\* Basis of calculations see page 197.

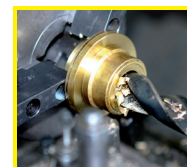

**Reworking within  
24h-service possible.  
Custom made parts  
on request.**