

Planetary Gear MPL

The low-backlash planetary gearheads are available in 11 ratios. They are characterized by their robust and short design. Due to the special design, the gearboxes have a high torsional stiffness and are also suitable for applications with high radial and axial forces. The gearboxes are available in 3 housing sizes \varnothing 50 mm, 70 mm and 90 mm.

- Lubrication: Fluid grease, lubricated for life.
- Any mounting position.
- Temperature range: -25°C to $+90^{\circ}\text{C}$.

The selection of the suitable motor depends on the application. The use of a stepper motor or servo motor is common. But other motor types can also be used.

Ordering Details: e.g.: Product No. 405 250 05, Planetary Gear MPL 50, Ratio 5:1

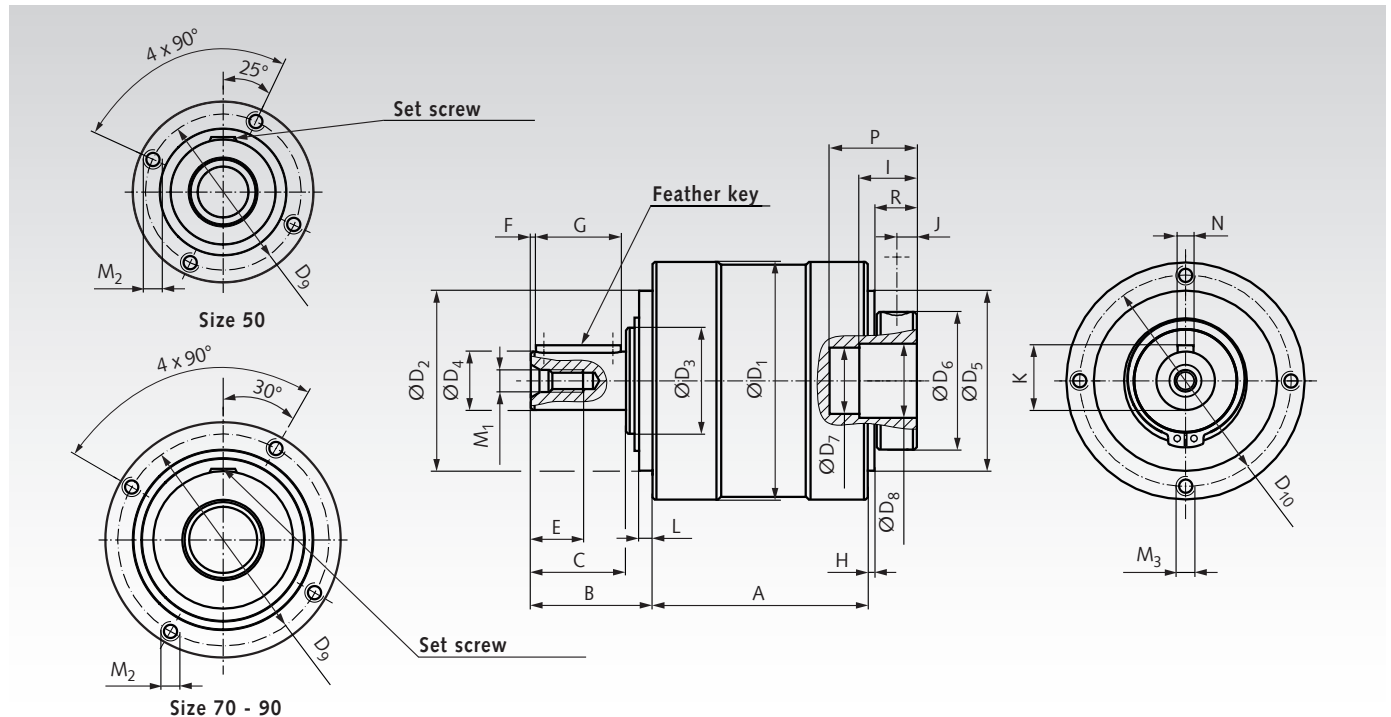

Size	Number of gear stages	A mm	Radial force* F_R N	Axial force* F_A N	Set screw DIN 913 - 45H mm	Width across flats SW mm	Fastening torque T_A Nm	Feather key DIN 6885 mm	Weight kg
50	1	48	650	700	M6 x 6	3	6	A4 x 4 x 14	0,6
	2	64							0,8
70	1	70	1450	1550	M8 x 8	4	10	A5 x 5 x 22	1,8
	2	91,5							2,3
90	1	84	2400	1900	M10 x 12	5	24	A6 x 6 x 32	3,7
	2	110							4,6

* The max. radial and axial forces refer to the middle of the output shaft and output speed 100 min^{-1} .

Size	B mm	C mm	D_1 mm	D_2^{h7} mm	D_3 mm	D_4^{k6} mm	D_5^{h7} mm	D_6 mm	D_7 mm	D_8^{F7} mm	D_9 mm	D_{10} mm	E mm
50	24,5	18	50	35	17	12	35	30	14	18	44	44	10
70	36	28	70	52	25	16	57	34	17	19	63	62	12,5
90	46	36	90	68	40	22	68	52	25	28	80	80	19
Size	F mm	G mm	H mm	I mm	J mm	K mm	L mm	M_1 mm	M_2 mm	M_3 mm	N^{h9} mm	P mm	R mm
50	2	14	2	9	5	13,5	4	M4	M4 x 5	M4 x 8	4	17,5	11
70	2,5	22	2	13,5	6,5	18,0	5	M5	M4 x 12	M5 x 10	5	25	13,5
90	2	32	2,5	20	8	24,5	5	M8	M6 x 20	M6 x 12	6	33	16

Planetary Gear MPL, Performance Data

i = transmission ratio.
 n_{1N} [min^{-1}] = nominal input speed.
 $n_{1\text{max}}$ [min^{-1}] = max. input speed.
 T_1 [Nm] = nominal input torque.
 $T_{2\text{zul}}$ [Nm] = permissible output torque (continuous operation).
 $T_{a\text{max}}$ [Nm] = max. acceleration torque at the output.
 $T_{2\text{max}}$ [Nm] = max. output torque.
 φ [arcmin] = backlash.
 η [%] = operating efficiency.
 C_t [Nm/arcmin] = torsional stiffness.
 J [kgcm^2] = mass moment of inertia.

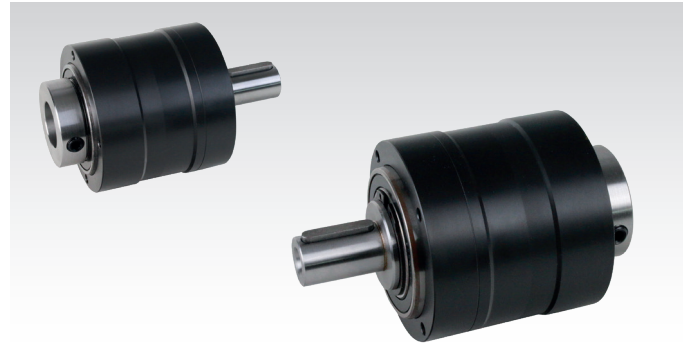

Motor adaption and reducing bush have to be ordered separately, see page N120.

Special versions on request.

Size	Product No.	Ratio i	Gear- stages	n_{1N} min^{-1}	$n_{1\text{max}}$ min^{-1}	T_1 Nm	$T_{2\text{zul}}$ ¹⁾ Nm	$T_{a\text{max}}$ ²⁾ Nm	$T_{2\text{max}}$ ³⁾ Nm	φ arcmin	η %	C_t Nm/arcmin	J ⁴⁾ kgcm^2
50	405 250 05	5 : 1	1	4000	8000	1,44	7	14	21	≤ 10	> 97	0,90	0,060
50	405 250 07	7 : 1	1	4000	8000	1,03	7	14	21	≤ 10	> 97	0,90	0,060
50	405 250 10	10 : 1	1	4000	8000	0,72	7	14	21	≤ 10	> 97	0,75	0,060
50	405 250 25	25 : 1	2	4000	8000	0,29	7	14	21	≤ 14	> 95	0,90	0,052
50	405 250 35	35 : 1	2	4000	8000	0,21	7	14	21	≤ 14	> 95	0,90	0,052
50	405 250 50	50 : 1	2	4000	8000	0,15	7	14	21	≤ 14	> 95	0,90	0,052
50	405 250 70	70 : 1	2	4000	8000	0,11	7	14	21	≤ 14	> 95	0,90	0,052
50	405 251 00	100 : 1	2	4000	8000	0,07	7	14	21	≤ 14	> 95	0,75	0,052
70	405 270 03	3 : 1	1	3700	6000	7,90	23	46	69	≤ 8	> 97	3,3	0,029
70	405 270 05	5 : 1	1	3700	6000	4,95	24	48	72	≤ 8	> 97	3,3	0,029
70	405 270 07	7 : 1	1	3700	6000	3,39	23	46	69	≤ 8	> 97	3,3	0,029
70	405 270 10	10 : 1	1	3700	6000	2,37	23	46	69	≤ 8	> 97	2,8	0,029
70	405 270 15	15 : 1	2	3700	6000	1,68	24	48	72	≤ 12	> 95	3,3	0,026
70	405 270 25	25 : 1	2	3700	6000	1,01	24	48	72	≤ 12	> 95	3,3	0,026
70	405 270 30	30 : 1	2	3700	6000	0,81	23	46	69	≤ 12	> 95	3,3	0,026
70	405 270 35	35 : 1	2	3700	6000	0,72	24	48	72	≤ 12	> 95	3,3	0,026
70	405 270 50	50 : 1	2	3700	6000	0,51	24	48	72	≤ 12	> 95	3,3	0,026
70	405 270 70	70 : 1	2	3700	6000	0,35	23	46	69	≤ 12	> 95	3,3	0,026
70	405 271 00	100 : 1	2	3700	6000	0,24	23	46	69	≤ 12	> 95	2,8	0,026
90	405 290 03	3 : 1	1	3400	6000	20,62	60	120	180	≤ 8	> 97	9	1,73
90	405 290 05	5 : 1	1	3400	6000	10,31	50	100	150	≤ 8	> 97	9	1,73
90	405 290 07	7 : 1	1	3400	6000	7,36	50	100	150	≤ 8	> 97	9	1,73
90	405 290 10	10 : 1	1	3400	6000	3,81	37	74	111	≤ 8	> 97	7,5	1,73
90	405 290 15	15 : 1	2	3400	6000	4,21	60	120	180	≤ 11	> 95	9	1,48
90	405 290 25	25 : 1	2	3400	6000	2,11	50	100	150	≤ 11	> 95	9	1,48
90	405 290 30	30 : 1	2	3400	6000	2,11	60	120	180	≤ 11	> 95	9	1,48
90	405 290 35	35 : 1	2	3400	6000	1,50	50	100	150	≤ 11	> 95	9	1,48
90	405 290 50	50 : 1	2	3400	6000	1,05	50	100	150	≤ 11	> 95	9	1,48
90	405 290 70	70 : 1	2	3400	6000	0,75	50	100	150	≤ 11	> 95	9	1,48
90	405 291 00	100 : 1	2	3400	6000	0,39	37	74	111	≤ 11	> 95	7,5	1,48

¹⁾ Lifetime 20,000 h at output speed 100 min^{-1} .

²⁾ max. 1,000 cycles per hr. $T_{a\text{max}}$ - Share $< 5\%$ of total running time.

³⁾ max. 1,000 cycles during the gearbox service life.

⁴⁾ related to the drive shaft.

Motor Adaptations for Planetary Gears MPS and MPL

Version for motor model B5

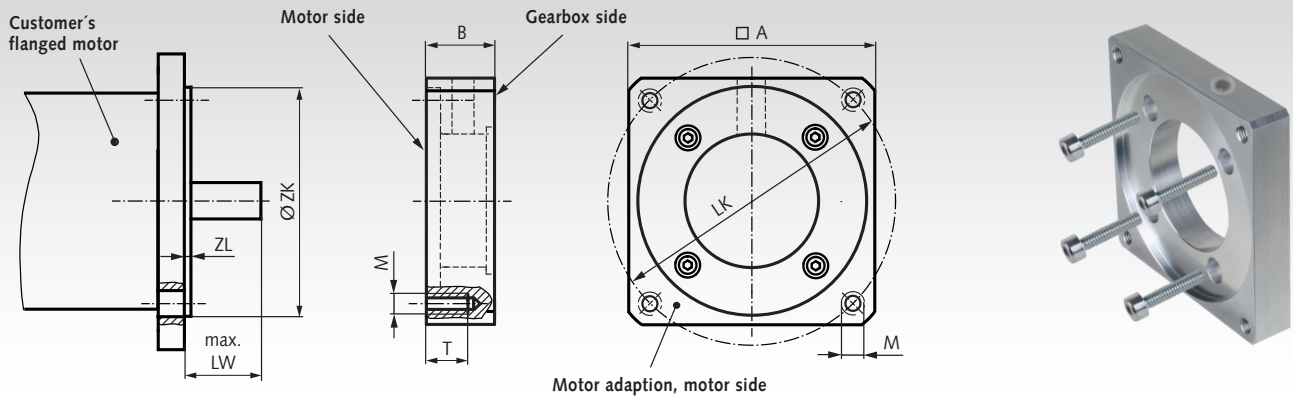

Product No.	suitable for	A mm	B mm	LK mm	LW mm	M mm	T mm	ZK mm	ZL mm	Weight g
405 340 40	MPS 40	55	18	63	23	M5	12	40	2,8	90
405 340 60	MPS 40	70	25	75	30	M5	18	60	3,5	220
405 360 40	MPS 60	60	20	63	23	M5	14	40	2,8	130
405 360 60	MPS 60	70	27	75	30	M5	16	60	3,5	250
405 360 70	MPS 60	80	37	90	40	M6	19	70	3,5	490
405 360 80	MPS 60	90	27	100	30	M6	19	80	3,5	450
405 380 60	MPS 80	80	23	75	30	M5	16	60	3,5	250
405 380 70	MPS 80	80	33	90	40	M6	19	70	3,5	380
405 380 80	MPS 80	90	23	100	30	M6	16	80	3,5	340
405 381 80	MPS 80	90	33	100	40	M6	20	80	3,5	510
405 380 95	MPS 80	100	33	115	40	M8	25	95	3,5	650

Product No.	suitable for	A mm	B mm	LK mm	LW mm	M mm	T mm	ZK mm	ZL mm	Weight g
405 450 40	MPL 50	55	17	63	20	M5	13	40	2,8	90
405 450 60	MPL 50	70	27	75	30	M5	19	60	3,5	250
405 470 40*	MPL 70	Ø73	17,5	63	23	M5	13	40	2,8	120
405 470 60	MPL 70	70	21,5	75	30	M5	15	60	3,5	170
405 470 70	MPL 70	80	31,5	90	40	M6	20	70	3,5	380
405 470 80	MPL 70	90	21,5	100	30	M6	**	80	3,5	320
405 490 60*	MPL 90	Ø93	21	75	30	M5	16	60	3,5	200
405 490 70	MPL 90	90	27	90	40	M6	20	70	3,5	340
405 490 80	MPL 90	90	27	100	30	M6	20	80	3,5	330
405 490 95	MPL 90	100	27	115	40	M8	22	95	3,5	440

The four fastening screws for mounting the flange to the gearbox are included in the scope of delivery. Other flange versions, such as design B14 (2-piece) and also for IEC motors, are available on request.

* This motor adaptation is round.

** This threadhole is a through-hole.

Ordering Details: e.g.: Product No. 405 340 40, Motor Adaption MPS 40, LK 63 mm, M5, ZK 40 mm

Reducing Bushes MPS and MPL

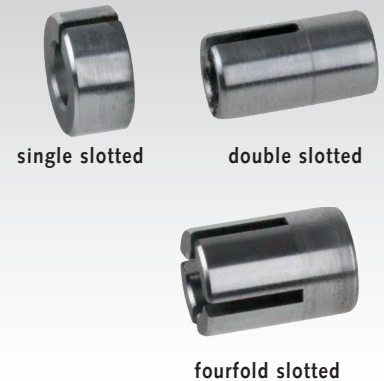
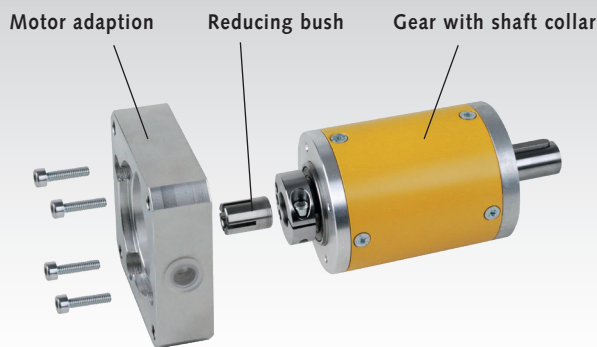

Product No.	suitable for	d mm	D mm	b mm	Weight g
405 540 06	MPS 40	6	9	17	4
405 560 09	MPS 60	9	14	20	12
405 560 11	MPS 60	11	14	20	8
405 580 11	MPS 80	11	19	25	32
405 580 14	MPS 80	14	19	25	24

Product No.	suitable for	d mm	D mm	b mm	Weight g
405 650 08	MPL 50	8	18	9	14
405 650 09	MPL 50	9	18	9	12
405 650 11	MPL 50	11	18	9	11
405 650 12	MPL 50	12	18	9	10
405 650 14	MPL 50	14	18	9	7
405 670 09	MPL 70	9	19	13,5	21
405 670 10	MPL 70	10	19	13,5	21
405 670 11	MPL 70	11	19	13,5	19
405 670 14	MPL 70	14	19	13,5	13
405 670 16	MPL 70	16	19	13,5	9
405 690 11	MPL 90	11	28	20	79
405 690 14	MPL 90	14	28	20	70
405 690 16	MPL 90	16	28	20	63
405 690 19	MPL 90	19	28	20	50
405 690 24	MPL 90	24	28	20	24

Reducing bushes for adapting motor with divergent shaft diameters. Depending on the type and size, the bushings are slotted 1-fold, 2-fold or 4-fold. **Please refer to the assembly instructions at www.maedler.de**

Ordering Details: e.g.: Product No. 405 540 06, Reducing Bush MPS 40, 6 x 9 x 17 mm