

Linear Bearings KB-ST-V with Square flange, Short Design

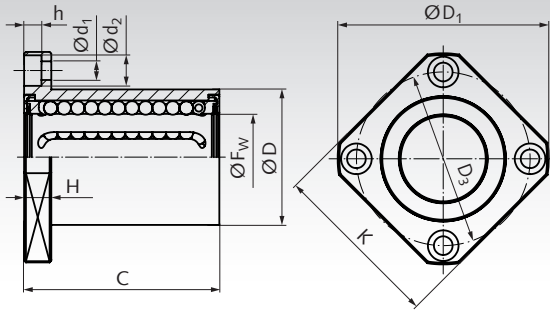

Material: With Steel jacket. Ball cage from plastic.

The linear ball bearings are suitable for screwing onto components. Via the four mounting holes, the linear bearings can be mounted directly e. g. in machines. This ensures easy mounting and interchangeability.

The bearings are greased at the factory. In order to prevent the ingress of dirt and the leakage of lubricant, the linear ball bearings are sealed on both sides.

Recommended shaft tolerance h6, housing tolerance H7.

Ordering Details: e.g.: Product No. 646 006 06V, Linear Bearing KB-ST-V, Internal-Ø 6 mm

Product No.	F _w mm	D mm	D ₁ mm	D ₃ mm	C ^{±0.3} mm	H mm	d ₁ x d ₂ x h mm	K mm	Load rating		Weight g
									dyn. C N	stat. C ₀ N	
646 006 06V	6	12	28	20	19	5	3,5 x 6 x 3,1	22	206	265	25
646 008 06V	8	16	32	24	25	5	3,5 x 6 x 3,1	25	265	402	50
646 012 06V	12	22	42	32	32	6	4,5 x 7,5 x 4,1	32	510	784	80
646 016 06V	16	26	46	36	36	6	4,5 x 7,5 x 4,1	35	578	892	110
646 020 06V	20	32	54	43	45	8	5,5 x 9 x 5,1	42	862	1370	190
646 025 06V	25	40	62	51	58	8	5,5 x 9 x 5,1	50	980	1570	340
646 030 06V	30	47	76	62	68	10	6,6 x 11 x 6,1	60	1570	2740	560
646 040 06V	40	62	98	80	80	13	9 x 14 x 8,1	75	2160	4020	1180
646 050 06V	50	75	112	94	100	13	9 x 14 x 8,1	88	3820	7940	1750
646 060 06V	60	90	134	112	125	18	11 x 17 x 11,1	106	4700	9800	3220

Tandem Linear Bearings KBT-ST-VL with Square flange, Long Design

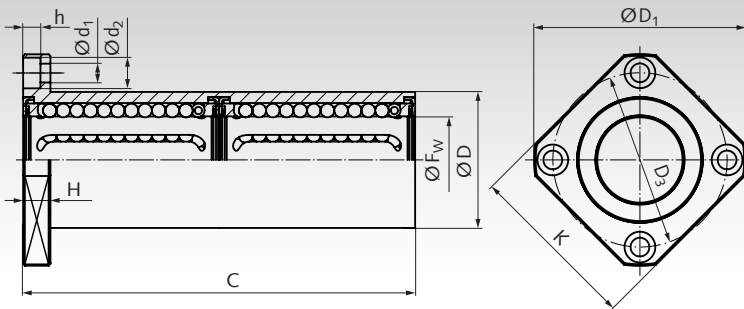

Material: With Steel jacket. Ball cage from plastic.

The linear ball bearings are suitable for screwing onto components. Via the four mounting holes, the linear bearings can be mounted directly e. g. in machines. This ensures easy mounting and interchangeability.

The bearings are greased at the factory. In order to prevent the ingress of dirt and the leakage of lubricant, the linear ball bearings are sealed on both sides.

Recommended shaft tolerance h6, housing tolerance H7.

Ordering Details: e.g.: Product No. 646 006 06VL, Tandem-Linear Bearing KBT-ST-VL, Internal-Ø 6 mm

Product No.	F _w mm	D mm	D ₁ mm	D ₃ mm	C ^{±0.3} mm	H mm	d ₁ x d ₂ x h mm	K mm	Load rating		Weight g
									dyn. C N	stat. C ₀ N	
646 006 06VL	6	12	28	20	35	5	3,5 x 6 x 3,1	22	323	530	30
646 008 06VL	8	16	32	24	46	5	3,5 x 6 x 3,1	25	421	804	60
646 012 06VL	12	22	42	32	61	6	4,5 x 7,5 x 4,1	32	813	1570	110
646 016 06VL	16	26	46	36	68	6	4,5 x 7,5 x 4,1	35	921	1780	160
646 020 06VL	20	32	54	43	80	8	5,5 x 9 x 5,1	42	1370	2740	260
646 025 06VL	25	40	62	51	112	8	5,5 x 9 x 5,1	50	1570	3140	540
646 030 06VL	30	47	76	62	123	10	6,6 x 11 x 6,1	60	2500	5490	820
646 040 06VL	40	62	98	80	151	13	9 x 14 x 8,1	75	3430	8040	1810
646 050 06VL	50	75	112	94	192	13	9 x 14 x 8,1	88	6080	15900	2820
646 060 06VL	60	90	134	112	209	18	11 x 17 x 11,1	106	7550	20000	4920

Shaft steel page 466. Shaft blocks page 475.