

## Sprockets KRS with One-Sided Hub, ANSI 25-1

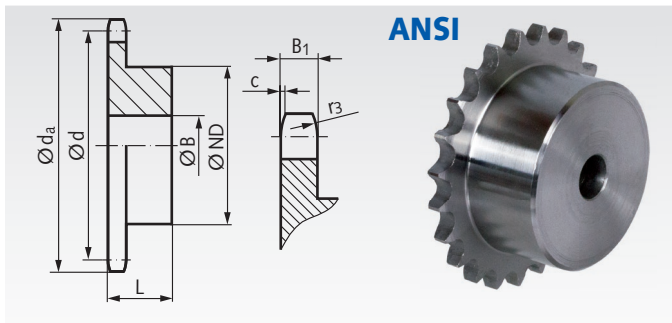

**Material:** Steel C45, not hardened.  
Pre-bored.

Ordering Details: e.g.: Product No. A10060800, KRS, ANSI 25-1, 8 Teeth

### ANSI 25-1 (ASA 04 C-1), Pitch 1/4"

$B_1 = 2.9$  mm,  $c = 0.7$  mm,  $r_3 = 6.4$  mm

Product No.	Number of teeth	$d_a$ mm	$d$ mm	ND mm	B mm	L mm	Weight g
A100 608 00	8	19,8	16,59	10	6	12	8
A100 609 00	9	21,8	18,57	11,5	6	12	11
A100 610 00	10	23,9	20,55	13	6	12	14
A100 611 00	11	25,9	22,54	15	8	13	17
A100 612 00	12	28,0	24,53	17	8	13	23
A100 613 00	13	30,0	26,53	17	8	13	25
A100 614 00	14	32,0	28,54	17	8	13	27
A100 615 00	15	34,0	30,54	20	8	13	36
A100 616 00	16	36,1	32,55	22	8	14	46
A100 618 00	18	40,1	36,57	25	8	14	60
A100 619 00	19	42,2	38,58	25	8	14	63
A100 620 00	20	44,2	40,59	25	8	14	66
A100 621 00	21	46,2	42,61	30	8	14	87
A100 622 00	22	48,2	44,62	30	8	14	90
A100 623 00	23	50,3	46,63	30	8	14	94
A100 624 00	24	52,3	48,65	30	8	14	97
A100 625 00	25	54,3	50,66	30	8	14	101
A100 626 00	26	56,3	52,68	30	8	16	115
A100 627 00	27	58,4	54,70	30	8	16	118
A100 628 00	28	60,4	56,71	30	8	16	122
A100 629 00	29	62,4	58,73	30	8	16	127
A100 630 00	30	64,4	60,75	30	8	16	131
A100 631 00	31	66,4	62,77	30	8	16	135
A100 632 00	32	68,5	64,78	30	8	16	140
A100 634 00	34	72,5	68,82	30	8	16	149
A100 635 00	35	74,5	70,84	30	8	16	154
A100 636 00	36	76,6	72,86	30	8	16	160
A100 637 00	37	78,6	74,88	30	8	16	165
A100 638 00	38	80,6	76,90	30	8	16	170
A100 639 00	39	82,6	78,91	30	8	16	176
A100 640 00	40	84,7	80,93	30	8	16	182

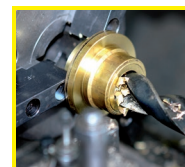

**Reworking within  
24h-service possible.  
Custom made parts  
on request.**