

## V-Belt Pulleys for Taper Bushes, Profile Z, SPZ and XPZ (10), 1 Groove

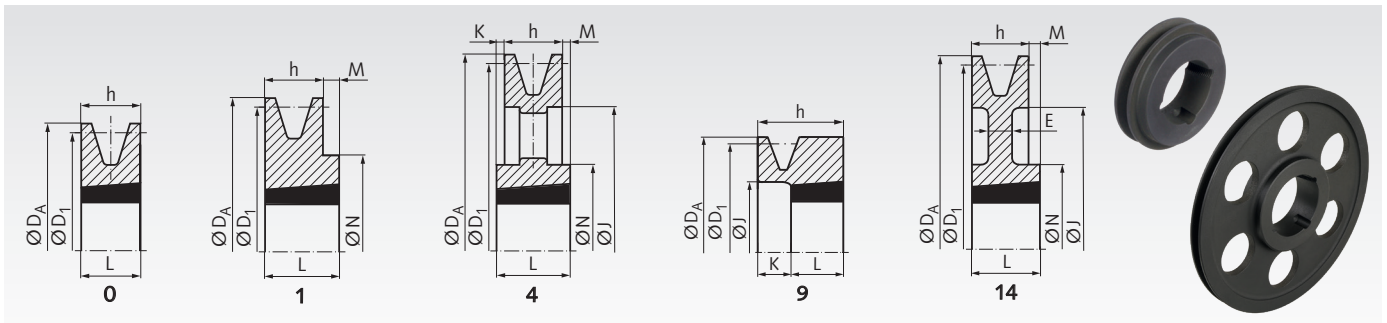

**Material:** cast iron EN-GJL-250, phosphated.

V-belt pulleys for taper bushes, for easy and fast mounting. The taper bush has to be ordered separately.

Regarding DIN 2211, DIN 2217 and ISO 4183, matching to classical V-belts DIN 2215 and narrow V-belts DIN 7753-1 / ISO 4184. Also suitable for V-belts 3V/9N according to ARPM/MPTA. The nominal diameter  $D_1$  is the datum diameter.

**Ordering Details:** e.g.: Product No. MAE 151-Z-1-50, V-Belt Pulley for Taper Clamping Bush, Profile Z, 1 Groove, Nominal Diameter 50 mm

Product No. Profile Z, SPZ, XPZ	No. of Grooves	Nominal Ø		Design	fitting Bush No.	Bore mm	E mm	h mm	J mm	K mm	L mm	M mm	N mm	Weight kg
		$D_1$ mm	$D_A$ mm											
MAE 151-Z-1-50	1	50 <sup>1)</sup>	54	9	1008	9 - 25	-	37	26	12	25	-	-	0,35
MAE 151-Z-1-56	1	56 <sup>2)</sup>	60	9	1008	9 - 25	-	37	32	12	25	-	-	0,50
MAE 151-Z-1-60	1	60 <sup>2)</sup>	64	0	1008	9 - 25	-	22	-	-	22	-	-	0,30
MAE 151-Z-1-63	1	63	67	1	1108	9 - 28	-	16	-	-	22	6	56	0,50
MAE 151-Z-1-67	1	67	71	1	1108	9 - 28	-	16	-	-	22	6	60	0,32
MAE 151-Z-1-71	1	71	75	1	1108	9 - 28	-	16	-	-	22	6	60	0,30
MAE 151-Z-1-75	1	75	79	1	1108	9 - 28	-	16	-	-	22	6	60	0,43
MAE 151-Z-1-80	1	80	84	1	1210	10 - 32	-	16	-	-	25	9	75	0,50
MAE 151-Z-1-85	1	85	89	1	1210	10 - 32	-	16	-	-	25	9	80	0,70
MAE 151-Z-1-90	1	90	94	1	1210	10 - 32	-	16	-	-	25	9	80	0,75
MAE 151-Z-1-95	1	95	99	1	1210	10 - 32	-	16	-	-	25	9	85	0,80
MAE 151-Z-1-100	1	100	104	1	1210	10 - 32	-	16	-	-	25	9	85	1,0
MAE 151-Z-1-106	1	106	110	1	1610	12 - 42	-	16	-	-	25	9	92	1,0
MAE 151-Z-1-112	1	112	116	1	1610	12 - 42	-	16	-	-	25	9	92	1,1
MAE 151-Z-1-118	1	118	122	1	1610	12 - 42	-	16	-	-	25	9	92	1,2
MAE 151-Z-1-125	1	125	129	1	1610	12 - 42	-	16	-	-	25	9	92	1,4
MAE 151-Z-1-132	1	132	136	1	1610	12 - 42	-	16	-	-	25	9	92	1,5
MAE 151-Z-1-140	1	140	144	1	1610	12 - 42	-	16	-	-	25	9	92	1,5
MAE 151-Z-1-150	1	150	154	1	1610	12 - 42	-	16	-	-	25	9	92	2,0
MAE 151-Z-1-160	1	160	164	1	1610	12 - 42	-	16	-	-	25	9	92	2,0
MAE 151-Z-1-170	1	170	174	1	1610	12 - 42	-	16	-	-	25	9	92	2,5
MAE 151-Z-1-180	1	180	184	14	1610	12 - 42	6	16	152	-	25	9	92	2,0
MAE 151-Z-1-190	1	190	194	14	1610	12 - 42	12	16	162	-	25	9	92	2,7
MAE 151-Z-1-200	1	200	204	14	2012	12 - 50	10	16	171	-	32	16	112	3,2
MAE 151-Z-1-224	1	224	228	14	2012	12 - 50	15	16	195	-	32	16	112	3,4
MAE 151-Z-1-250	1	250	254	4	2012	12 - 50	-	16	221	8	32	8	112	3,6
MAE 151-Z-1-280	1	280	284	4	2012	12 - 50	-	16	251	8	32	8	112	5,5
MAE 151-Z-1-315	1	315	319	4	2012	12 - 50	-	16	286	8	32	8	112	7,0
MAE 151-Z-1-355	1	355	359	4	2012	12 - 50	-	16	326	8	32	8	112	6,0
MAE 151-Z-1-400	1	400	404	4	2012	12 - 50	-	16	371	8	32	8	112	6,2
MAE 151-Z-1-450	1	450	454	4	2517	15 - 65	-	16	421	14,5	45	14,5	124	7,0

<sup>1)</sup> Not for V-belts SPZ, XPZ and 3V/9N. Material: Steel C45, phosphated.

<sup>2)</sup> Not for V-belts SPZ and 3V/9N. Material: Steel C45, phosphated.

### Taper Bushes

The bushes are available with various outer dimensions. For every outside measure there are bushes with many different bores available. They can be used with and without key.

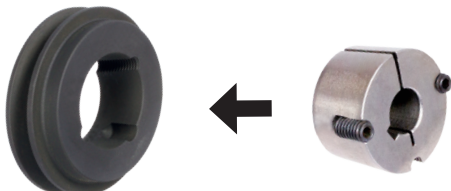

### Mounting

Videos are available on our homepage and on YouTube. The instructions are available as a PDF file in the online shop and on paper in the scope of delivery of the bush.

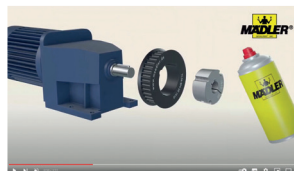

**D** [www.maedler.de](http://www.maedler.de)  
**A** [www.maedler.at](http://www.maedler.at)  
**CH** [www.maedler.ch](http://www.maedler.ch)