

Splined Shafts and Splined Hubs DIN ISO 14 – Description

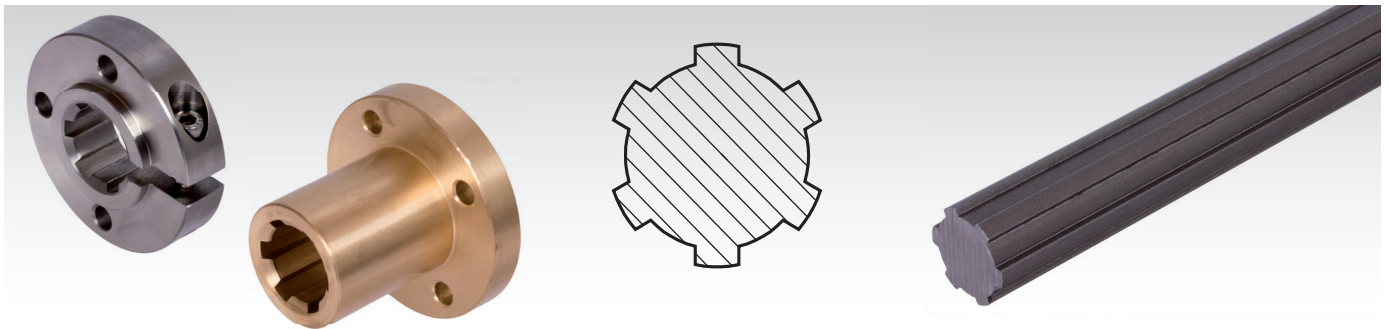

General Description

Splined shafts with splined hubs are used when torques have to be transmitted and the component to be driven needs to be movable in axial direction.

Common Profiles

DIN ISO 14 (used to be DIN 5463): Most common type, with straight, parallel flanks. This is the profile of catalogue goods. Other standards are less commonly used.

Profile Description DIN ISO 14:

Number of splines x small diameter x big diameter. Example for a component with 6 splines and outside diameter 14 mm: splined shaft (KW) or splined hub (KN) 6 x 11 x 14.

Production method:

Cold drawn: Economical production method. Due to the chipless shaping, the shafts have a unsevered grain structure and thus a high strength. This production method is perfectly suited for easy to shape materials as C45, 42CrMo4 or 1.4301.

Milled: for single-unit production, if special dimensional accuracy is required or for high strength materials. With this methods, shafts with diameters (steps) that are larger than the core diameter or outside diameter can be produced.

Splined Shafts in Catalogue Version, Page 531

Profiles

Main dimensions in accordance with DIN ISO 14. Shaft with splines with parallel, straight flanks. Up to size 28 x 34 with six splines, from size 32 x 38 with 8 splines.

Materials

The catalogue splined shafts are cold drawn. They are optionally available in steel C45, steel 42CrMo4 or stainless steel 1.4301.

Tolerances

Straightness 0.8 mm/m, Torsion max. 0.5 mm/m. A straightness of 0.1mm/m can be produced on request.

Lengths

Splined shafts up to a length of 6 metres can be supplied from stock. Standard lengths sold are 1 metre, 1.5 metre, 2 metres, 3 metres and 6 metres. Price for customized lengths up to 6 metres on request.

Splined Hubs in in Catalogue Version, Page 532

Profile

Main dimensions in accordance with DIN 14. Hub with splines with parallel, straight flanks. Up to size 28 x 34 with six splines, from size 32 x 38 with 8 splines.

Materials

The catalogue splined hubs are optionally available in steel C45, red brass or stainless steel 1.4301. Other materials as e.g. 42CrMo4 on request.

Tolerances

Profile inner diameter: H7. Profile outside diameter: H11. Outer dimensions: according to DIN 2768m.

Lengths

The standard lengths are equivalent to the maximum possible sweeping length. Longer splined hubs are available on request. Provide for at least one centred (or one-sided) relieve groove.

Torque- and Performance Figures of Splined Shafts based on the Torsional Stress (with Safety Margin of 2.5)

Material C45

Profile	11 x 14	13 x 16	16 x 20	18 x 22	21 x 25	23 x 28	26 x 32	28 x 34	32 x 38	36 x 42	42 x 48	46 x 54
Nm* fluctuating	38,1	59,5	103	141	215	293	373	455	655	906	1106	1455
Nm* alternating	33,3	52,0	90	124	189	257	326	398	573	793	973	1280
kW** fluctuating	6,0	9,3	16	22	34	46	59	72	103	142	174	230
kW** alternating	5,2	8,2	14	20	30	40	51	62	90	124	153	200

Material 42CrMo4

Profile	11 x 14	13 x 16	16 x 20	18 x 22	21 x 25	23 x 28	26 x 32	28 x 34	32 x 38	36 x 42	42 x 48	46 x 54
Nm* fluctuating	59	93	161	220	335	457	582	710	1022	1413	1725	2270
Nm* alternating	53	82	142	196	299	406	515	629	905	1253	1537	2022
kW** fluctuating	9,3	15	25	34	53	72	92	112	161	222	271	359
kW** alternating	8,3	13	22	32	47	63	81	98	142	196	242	316

Material 1.4301

Profile	11 x 14	13 x 16	16 x 20	18 x 22	21 x 25	23 x 28	26 x 32	28 x 34	32 x 38	36 x 42	42 x 48	46 x 54
Nm* fluctuating	16,4	25,5	49	67	102	139	204	249	359	496	763	1005
Nm* alternating	14,4	22,5	43	59	90	122	180	220	316	437	672	885
kW** fluctuating	2,6	4,0	8	10	16	22	32	39	56	78	120	160
kW** alternating	2,3	3,5	7	9	14	19	28	34	50	69	106	140

* Transmittable torque in Nm.

** Transmittable power in kW at 1500 min⁻¹.